





## Dear Customer

This Getting Started contains information about the daily use of your Bang & Olufsen product. We expect your retailer to deliver, install and set up your product.

In order to use your BeoSound 5 Encore as a navigation panel for your digital music collection and more than 10,000 radio stations world-wide, the music system must be connected to the internet and to a digital music library source of your choice.

You can find information about how to make your digital music available in the product's on-line Guide on [www.bang-olufsen.com/guides](http://www.bang-olufsen.com/guides). This Guide describes additional features and functions such as language and pincode settings and how to operate your product with a Bang & Olufsen remote control.

On [www.bang-olufsen.com](http://www.bang-olufsen.com) you can also find further information and relevant FAQs about your product.

Your Bang & Olufsen retailer is your first stop for all your queries.

*To find your nearest retailer, visit our website ...*

[www.bang-olufsen.com](http://www.bang-olufsen.com)

**WARNING:** To reduce the risk of fire or electric shock, do not expose this appliance to rain or moisture. Do not expose this equipment to dripping or splashing and ensure that no objects filled with liquids, such as vases, are placed on the equipment.

To completely disconnect this equipment from the AC Mains, disconnect the mains plug from the wall socket. The disconnect device shall remain readily operable.



The lightning flash with arrowhead symbol within an equilateral triangle, is intended to alert the user to the presence of uninsulated "dangerous voltage" within the product's enclosure that may be of sufficient magnitude to constitute a risk of electric shock to persons.



The exclamation point within an equilateral triangle is intended to alert the user to the presence of important operating and maintenance (servicing) instructions in the literature accompanying the product.

***Important!***

- Avoid placing the product in direct sunlight or direct artificial light, such as a spotlight.
- Make sure that the product is set up, placed and connected in accordance with the instructions.
- Place your product on a firm surface or stand where you want it placed permanently. Use Bang & Olufsen approved stands and wall brackets only!
- Do not place any items on top of your product.
- No naked flame sources, such as lighted candles should be placed on the apparatus.
- Do not subject the product to high humidity, rain or sources of heat.
- The product is intended for indoor use in dry, domestic environments only. Use within a temperature range of 10–40°C (50–105°F).
- If the product has been exposed to temperatures below 5°C (40°F), leave it at room temperature and wait until the product has regained normal room temperature before it is connected to the mains and switched on.
- Leave enough space around the product for adequate ventilation.
- Do not connect any of the products in your system to the mains, until you have connected all the cables.
- Do not attempt to open the product. Leave such operations to qualified service personnel.
- The product can only be switched off completely by disconnecting it from the wall socket.

# Contents

- 6 How to use your music system
- 7 The display
- 8 Listen to your music
- 10 MOTS, play queues and favourites
- 12 Listen to internet radio
- 14 Set up your music system
- 15 Cleaning
- 16 Connections
- 18 What to do if ...

## How to use your music system

The music system is designed for close-up operation. You use the pointer, the wheel and the buttons to operate.

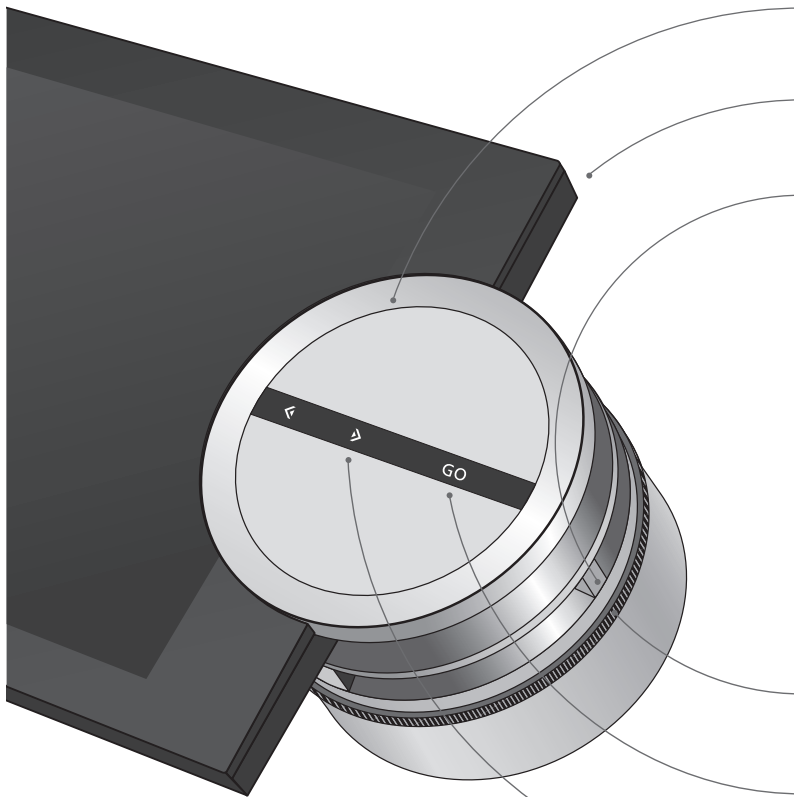

The wheel: Scroll lists of content or browse in menus.



Standby.



The pointer: Move the 'laser-beam' between views and menus along the 'Arc' to the left.



Turn to adjust volume.

GO

Activate display. Confirm selection. Play or pause track or bring up sub-menus.

>

Close sub-menu or go to next track or station in Player mode. Leave SETTINGS menus without storing.

<

Open sub-menu or select item. Go to previous track or station in Player mode.

## Important

### **Symbols** **Remote control**

The symbols shown above are used in this Getting Started to explain how to operate the music system. The product can also be operated by remote control. This and more is explained in the Guide found on [www.bang-olufsen.com/guides](http://www.bang-olufsen.com/guides).

The display has two different modes: Browser mode and Player mode. You can do different things when in Player and Browser mode.

The 'Arc' – select items along the Arc with the pointer

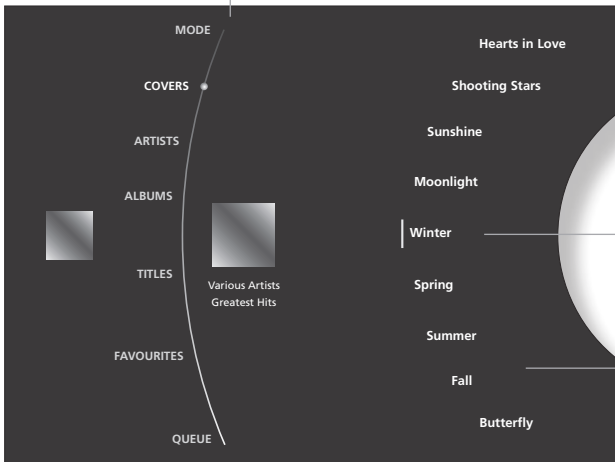

### Browser mode

In Browser mode, you can look through the content on your music system without interrupting playback. You can add music to make your own play queues or 'plant a seed' to auto-generate a MOTS play queue.

The 'Wheel focus' – shows the current selection and focus of operation. A vertical line in front of an item shows that something new starts, for example; a new album.

The 'Wheel list' – shows lists of content.

You enter Browser mode by pressing the GO button.



### Player mode

In Player mode, you can see what is playing. Use the buttons to pause playback or step to the next/previous track or radio station, and turn the volume wheel to adjust volume.

You can also use a Bang & Olufsen remote control to perform these operations.

MOTS icon – shows that the music playing is generated by MOTS.

The display enters Player mode automatically 3 minutes after the last operation. To activate Player mode faster, just move the pointer to the top or bottom of the display.

**Start-up time** The start-up time of your music system depends on the POWER SAVING setting. See the Guide for more information.

## Listen to your music

To activate the display from standby, just press the GO button. You can now browse your music collection to find the music you want to listen to.

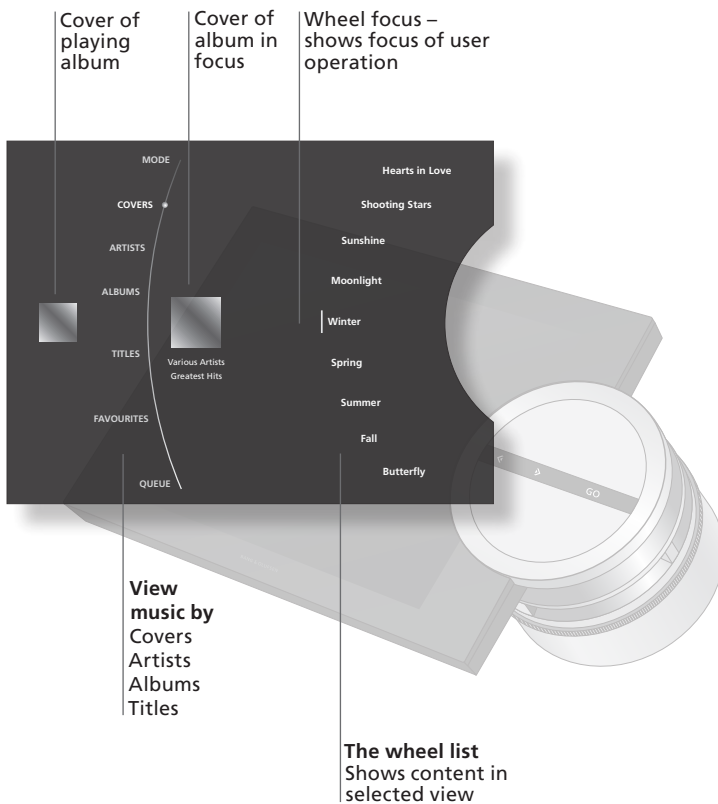

## BeoSound 5 Encore Operation

### Start N.MUSIC

The music system starts from the beginning of the last played track.

### Browse music

Browse your music without interfering with the current track.

### Pause or resume

In Player mode, you can pause or resume playback of the current track.

### Play specific track

Select a specific track by artist, album or cover.

### Next or previous

In Player mode, you can step to the next or previous track.

### Switch off

## Important information

**Music** To listen to N.MUSIC, your music system must be connected to a digital music source, for example a hard disc, a DLNA server (NAS), a computer, USB stick or handheld device. For information about how to connect your preferred sources, refer to page 16 in this Getting Started and to the Guide.





Highlight  
MODE



Select  
N.MUSIC+<sup>1</sup>



Confirm



Highlight a  
view



Browse



Open



Browse

GO

Press once to pause and again  
to resume



Highlight a  
view



Browse



Open



Browse



Confirm



Previous or next track



Press

**Remote control  
Views**

Remote control operation is explained in the Guide found on [www.bang-olufsen.com/guides](http://www.bang-olufsen.com/guides). Available views in N.MUSIC are COVERS, ARTISTS, ALBUMS and TITLES. Albums without a cover are shown with a default cover.

<sup>1</sup> **N.MUSIC** Select the 'name' of the music source you want to use (A.MEM, CD or N.MUSIC).

# MOTS, play queues and favourites

You can decide the playback order of your music, or let the music system generate a MOTS play queue for you. The last track you add to your play queue always serves as a MOTS 'seed'.

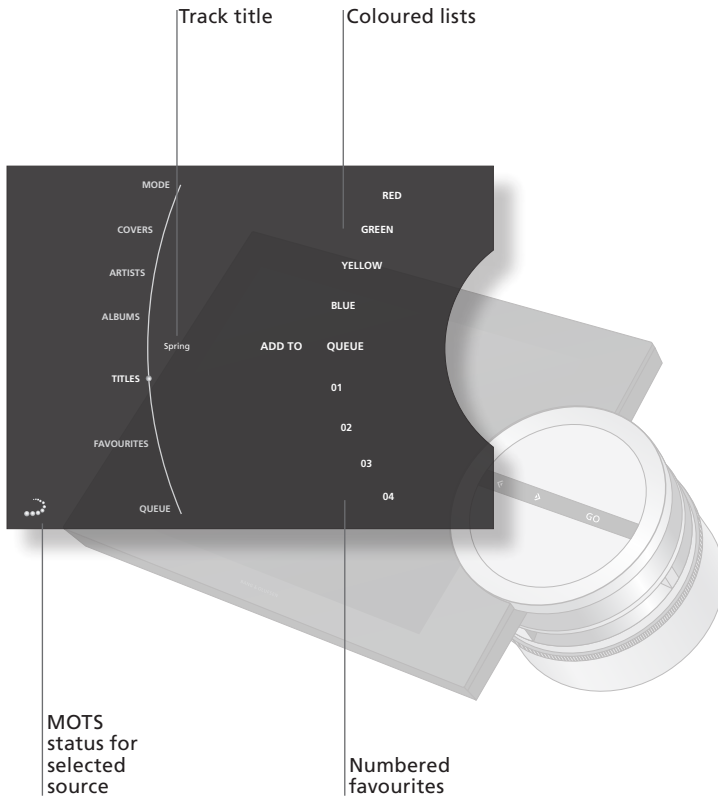

## BeoSound 5 Encore Operation

### Start N.MUSIC

The music system starts from the beginning of the last played track.

### Seed MOTS

Use a track as seed to auto-generate an endless sequence of similar tracks.\*<sup>1</sup>

### Make a play queue

Add track, album or artist to the play queue.

### Play queue

Play from the play queue.\*<sup>2</sup>

### Remove from queue























Remove track, album or artist from the play queue.

### Play favourites

Browse in four coloured lists and 99 numbered favourites.\*<sup>3</sup>

## Information

<sup>1</sup>\* **MOTS** The idea of MOTS is that you 'plant a seed' by selecting a track, and this seed will then grow into a list of similar music. Once you start playing a track, it will continue to play similar music. To generate a MOTS play queue, the music system always uses the last added track in the play queue.

					
Highlight MODE	Select N.MUSIC	Confirm			
					
Select track	Activate Player mode	Press and hold			
					
Select track, album or artist	Press and hold	Select 'ADD TO QUEUE'	Confirm		
					
Highlight QUEUE	Select track	Confirm			
					
Highlight QUEUE	Select item to remove	Press and hold to reveal options	Select REMOVE	Confirm	
			or		
Highlight FAVOURITES	Select coloured list	Confirm		Select numbered favourite	Confirm

<sup>2\*</sup> **Play queue** The play queue shows the list of music items (tracks, albums, etc.) you have selected for playback.

<sup>3\*</sup> **Favourites** You can place your favourite music in coloured lists and numbered favourites to be able to select it quickly with the remote control. For further information, see the Guide on [www.bang-olufsen.com/guides](http://www.bang-olufsen.com/guides)

## Listen to internet radio

With internet radio you have easy access to radio stations worldwide.

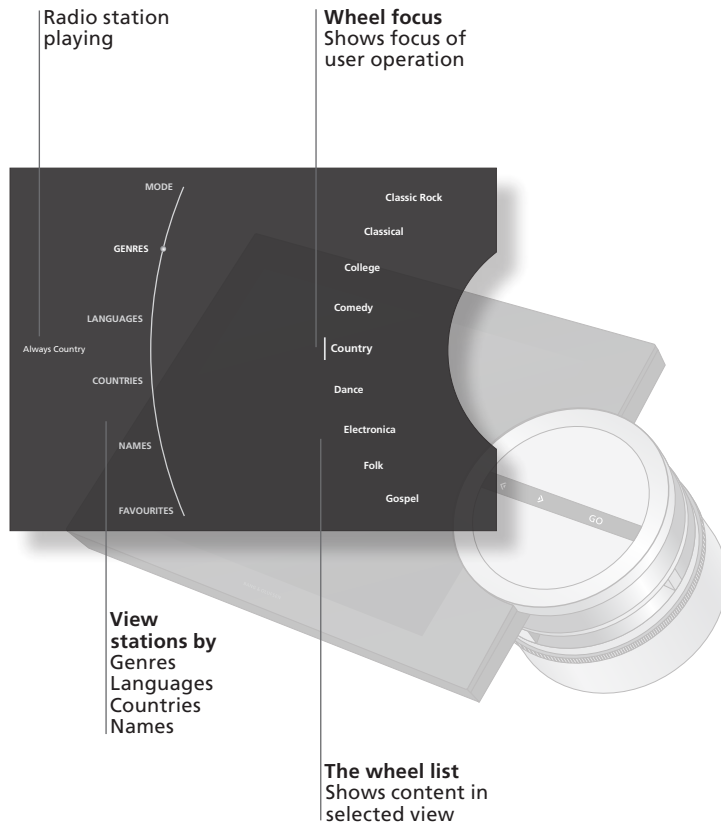

### BeoSound 5 Encore Operation

#### Start RADIO

The music system starts automatically on the last played station.

#### Find station by view

Select station by GENRES, LANGUAGES, COUNTRIES or NAMES.

#### Next or previous

In Player mode, play the next or previous radio station.

#### Add a station as favourite

Make a radio station a numbered favourite.

#### Play a favourite

Browse in four coloured lists and 99 numbered favourites.

## Information

**Internet connection** To listen to internet radio, your music system must be connected to the internet.



Highlight MODE



Select RADIO

GO

Confirm



Highlight a view



Browse



Open



Browse

GO

Select

Move to top or  
bottom for Player  
modePrevious or next  
station in Player modeSelect radio  
stationPress and  
holdSelect 'ADD TO'  
an available  
number

Confirm

Highlight  
FAVOURITESSelect list or  
numbered favourite

GO

Play

**Favourites** If you own a Bang & Olufsen remote control, you can use it to play a numbered station immediately, simply press the digit corresponding to the numbered station. To play a specific station in a coloured list, press the coloured button followed by the digit.

**NOTE!** The radio stations are automatically updated on a regular basis to reflect only the stations currently available.

## Set up your music system

The music system must be placed on a wall, or on one of the optional accessories. Follow the instructions below to place the music system on a wall – using the standard wall bracket.

### Place the wall bracket

Find the correct place for the music system. Use the enclosed wall bracket and spacer as a template to mark up where to drill the holes. To make sure the wall bracket is level, place a spirit level on top of the two designated supports (A).

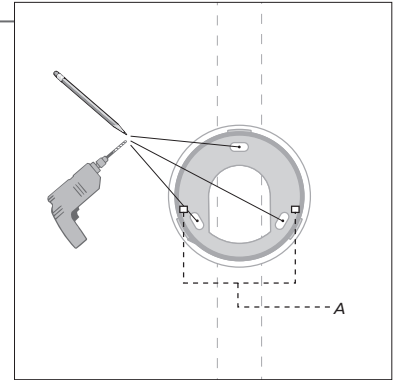
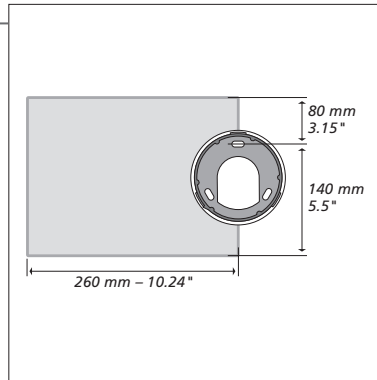

### Fasten the wall bracket

Use the appropriate size and type of screws and wall plugs – taking into account the construction and condition of the wall. Use three screws/ fasteners with a minimum load rating of 3.5 kg (8 lbs.).

Before you fasten the music system on the wall bracket, insert the cables into the corresponding sockets of the cylinder on the back of the music system (B). For information about sockets, refer to page 16.

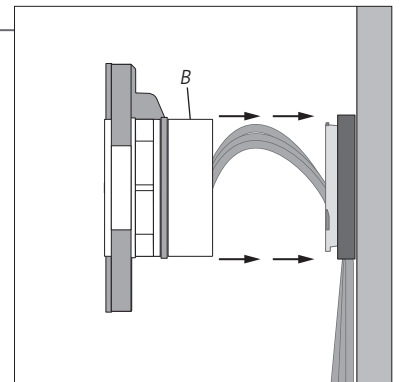
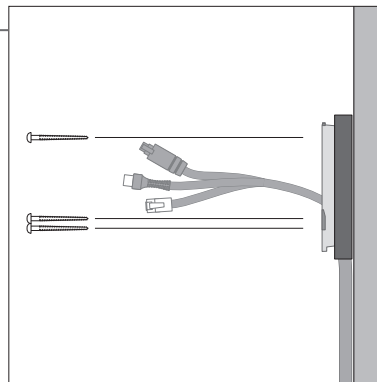

## Information

### Light partition walls

If you intend to hang the music system on a gypsum wall (also known as drywall or wallboard), the wall bracket must be fastened to a vertical stud. Use one lag screw (5 mm – 0.2"), which penetrates the gypsum, and is screwed a minimum of 25 mm (1") into a vertical stud. For stability, use two additional screws of a type intended for gypsum walls. Mounting was evaluated for use on a drywall surface.

### Fasten the music system

Turn the cylinder clockwise as far as it goes. Insert a pencil or similar into the small hole on the outer side of the cylinder to gently unlock the locking mechanism, as shown (1).

Then turn the cylinder clockwise as far as it will go. One of the 'cut-outs' in the cylinder must be in a 12 o' clock position, as shown (2).

Now fit the music system onto the wall bracket (3) and turn the cylinder clockwise to tighten until the music system is fastened securely on the wall (4).

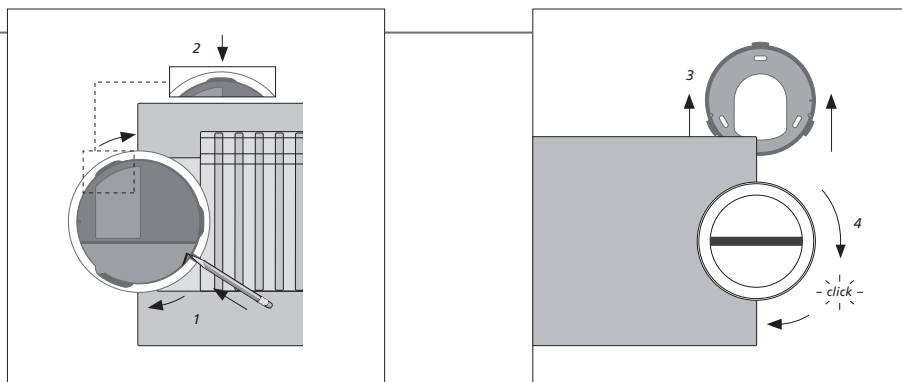

### Dismount the music system

Face the music system from the front:

Turn the cylinder counter-clockwise as far as it goes. Insert a pencil or similar into the small hole on the outer side of the cylinder and gently unlock the locking mechanism, as shown (1).

Then turn the cylinder counter-clockwise as far as it will go (2).

Disconnect the cables from the socket panel.

NOTE! The product is heavy and must be handled with care.

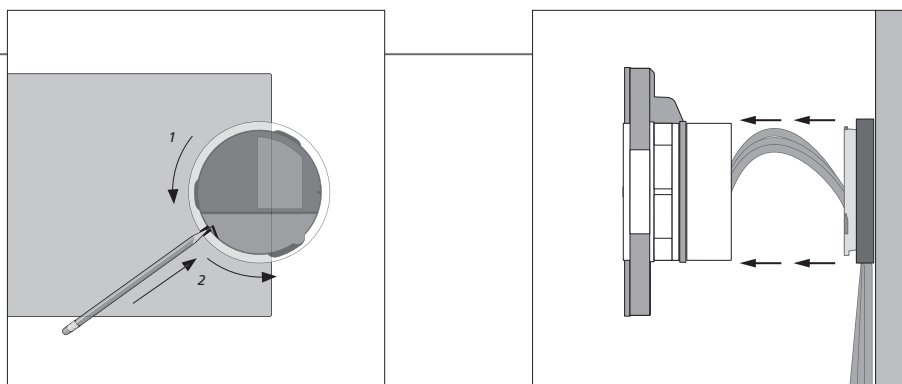

## Cleaning

**Display** Use a soft, dry cloth to wipe dust off the music system. Do not use liquid cleaners or aerosol cleaners.

**Cabinet and controls** Wipe dust off the surfaces using a dry, soft cloth. To remove stains or dirt, use a soft, damp cloth and a solution of water and mild detergent, such as washing-up liquid.

NOTE! Regular maintenance, such as cleaning, is the responsibility of the user.

# Connections

To use BeoSound 5 Encore as a navigation panel for your music collection, one or several digital music sources must be connected.

## Connections

The permanent sockets are placed on the back side of the music system, whereas sockets for temporary use are easily accessible below the display.

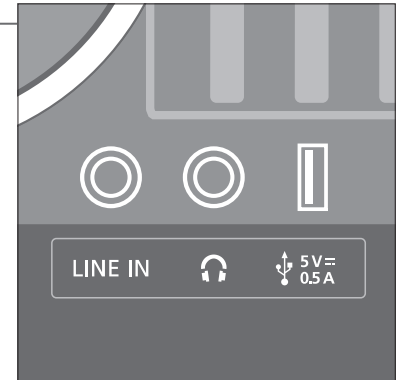
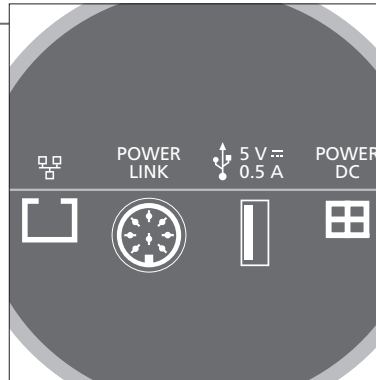

### ETHERNET CONNECTION\*<sup>1</sup>

#### POWER LINK

Power Link socket for loudspeaker connection

*Loudspeaker connections – Power Link*  
Connect your active speakers to the socket marked Power Link and loop the signal through from speaker to speaker. Refer to the Guides for the BeoLab loudspeakers.



#### USB

USB connection – for permanent music storage on external hard disc drive.

#### POWER

Connect the music system to the mains using the supplied power supply.\*<sup>2</sup>

#### LINE IN

Line-in connection – for connection of an MP3 player such as an iPod.



#### Headphone connection

When headphones are plugged in, the speakers, connected to your music system, are muted.

*NOTE! Prolonged listening at a high volume level may cause hearing damages!*



#### USB

USB connection – for temporary music storage on a USB stick.

## Important information

**Connections** For more information about connections, see the Guide on [www.bang-olufsen.com/guides](http://www.bang-olufsen.com/guides).

**\* Power supply** For information about how to connect the music system to the mains using the supplied power supply, please refer to its own Guide.

<sup>1\*</sup> For access to internet radio, DLNA server (NAS), 3<sup>rd</sup> party server, BeoSound 5/BeoMaster 5 setup, etc. **NOTE!** Only connect to a local area network (LAN) that does not exit your house or building.





## What to do if ...

If you want to ...	Then ...
Enter pincode on start-up ...	Use the wheel to enter the digits in your pincode. Use the arrow button left < or <b>GO</b> to add a digit. Use the arrow button right > to remove previously entered digits. To store the entered pincode, turn the wheel and select <b>STORE</b> , then press <b>GO</b> . For further information about pincode, see the Guide.
Switch between sources ...	Use the pointer to select <b>MODE</b> . Then turn the wheel to choose between available sources, and press <b>GO</b> to confirm.
Find out why a source is not available ...	If the source you want to select does not appear in the <b>MODE</b> menu, it is most likely because it is not connected. Make connections and try again.
Add a track to the play queue ...	Use the pointer to select a view, e.g. Albums. Then turn the wheel to browse in the selected view (use the left arrow < to unfold the view, if necessary) and turn the wheel again to find the track you want to add to the play queue. When the track is selected, press and hold <b>GO</b> , then scroll the wheel to select <b>ADD TO QUEUE</b> and press <b>GO</b> .
See the play queue ...	Move the pointer to select <b>QUEUE</b> and the play queue appears in the wheel list to the right.
Clear the play queue ...	Use the pointer to select <b>QUEUE</b> , then turn the wheel to select a random track. Now press and hold <b>GO</b> , turn the wheel to select <b>CLEAR QUEUE</b> and press <b>GO</b> .
Remove a track from the play queue ...	Use the pointer to select <b>QUEUE</b> , then turn the wheel to find the track you wish to remove. Now press and hold <b>GO</b> , scroll the wheel to select <b>REMOVE</b> and press <b>GO</b> .
Use a track as MOTS seed ...	The last track in the play queue always serves as MOTS seed, also when you play a coloured list or a numbered favourite. See page 10.
Make a coloured list ...	Turn the wheel to find the item (track, album, artist or radio station), you wish to add to a coloured list. Then press and hold <b>GO</b> , turn the wheel to select a colour and press <b>GO</b> to confirm. Note that you cannot add music from two different music sources to a coloured list, each music source has its own favourite lists.
Play a coloured list ...	Activate <b>N.MUSIC</b> . Turn the wheel to select <b>FAVOURITES</b> and press <b>GO</b> , turn the wheel to select the coloured list you want and press <b>GO</b> .
Change the display language ...	Use the pointer to select <b>MODE</b> , then turn the wheel to select <b>SETTINGS</b> and use the pointer again to highlight <b>SYSTEM SETTINGS</b> . Now turn the wheel to select <b>LANGUAGE</b> and press <b>GO</b> , then turn the wheel to select language and press <b>GO</b> .

---

## Important information

**Guide** To learn more about your music system, look up the Guide on [www.bang-olufsen.com/guides](http://www.bang-olufsen.com/guides) or see the FAQ section on our website.





*This product is in conformity with the provisions of the Directive 1999/5/EC (R&TTE).*

AT, BE, BG, CH, CY, CZ, DE, DK, EE, ES, FI, FR, GB, GR, HU, IE, IS, IT, LI, LT, LU, LV, MT, NL, NO, PL, PT, RO, SE, SI, SK, TR.

Hereby, Bang & Olufsen declares that this Audio System with WLAN is in compliance with the essential requirements and other relevant provisions of Directive 1999/5/EC. The Declaration of Conformity may be consulted at [www.bang-olufsen.com/guides](http://www.bang-olufsen.com/guides).

This product incorporates copyright protection technology that is protected by U.S. patents and other intellectual property rights. Use of this copyright protection technology must be authorized by Rovi, and is intended for home and other limited viewing uses only unless otherwise authorized by Rovi. Reverse engineering or disassembly is prohibited.

HDMI, the HDMI logo and High-Definition Multimedia Interface are trademarks or registered trademarks of HDMI Licensing LLC.

The distance from the human hand to the transmitter antenna during normal use of this product will be at least 6 cm, which is more than the RF exposure safety distance of 4 cm.

Bang & Olufsen cannot vouch for the quality of net radio stations available from programme providers.

#### ***For the US-market only!***

Changes or modifications not expressly approved by the party responsible for compliance could void the user's authority to operate the equipment.

This device complies with part 15 of the FCC Rules. Operation is subject to the following two conditions: (1) this device may not cause harmful interference, and (2) this device must accept any interference received, including interference that may cause undesired operation.

NOTE: This equipment has been tested and found to comply with the limits for a class B digital device, pursuant to part 15 of the FCC Rules. These limits are designed to provide reasonable protection against harmful interference in a residential installation. This equipment generates, uses and can radiate radio frequency energy and, if not installed and used in accordance with the instructions, may cause harmful interference to radio communications. However, there is no guarantee that interference will not occur in a particular installation. If this equipment does cause harmful interference to radio or television reception, which can be determined by turning the equipment off and on, the user is encouraged to try to correct the interference by one or more of the following measures:

- Reorient or relocate the receiving antenna.
- Increase the separation between the equipment and receiver.

- Connect the equipment into an outlet on a circuit different from that to which the receiver is connected.
- Consult the retailer or an experienced radio/TV technician for help.

#### ***For the Canadian market only!***

This class B digital apparatus meets all requirements of the Canadian Interference-Causing Equipment Regulations.

This device complies with Industry Canada licenceexempt RSS standard(s). Operation is subject to the following two conditions: (1) this device may not cause interference, and (2) this device must accept any interference, including interference that may cause undesired operation of the device.

Under Industry Canada regulations, this radio transmitter may only operate using an antenna of a type and maximum (or lesser) gain approved for the transmitter by Industry Canada. To reduce potential radio interference to other users, the antenna type and its gain should be so chosen that the equivalent isotropically radiated power (e.i.r.p.) is not more than that necessary for successful communication.

This radio transmitter (3775A-SMALLENGINE) has been approved by Industry Canada to operate with the antenna types listed below with the maximum permissible gain and required antenna impedance for each antenna type indicated. Antenna types not included in this list, having a gain greater than the maximum gain indicated for that type, are strictly prohibited for use with this device: Tyco Electronics Antenna 1551359-1, Gain 5dBi, Impedance 50 Ohm.

This equipment complies with IC RSS-102 radiation exposure limits set forth for an uncontrolled environment. This equipment should be installed and operated with a minimum distance 20 cm between the radiator and your body.

Please note that high-power radars are allocated as primary users (i.e. priority users) of the bands 5250-5350 MHz and 5650-5850 MHz and these radars can cause interference and/or damage to LE-LAN (License-exempt Local Area Network) devices.

**Waste Electrical and Electronic Equipment (WEEE) – Environmental protection**

Electrical and electronic equipment, parts and batteries marked with this symbol must not be disposed of with normal household wastage; all electrical and electronic equipment, parts and batteries must be collected and disposed of separately.

When disposing of electrical and electronic equipment and batteries by use of the collection systems available in your country, you protect the environment, human health and contribute to the prudent and rational use of natural resources. Collecting electrical and electronic equipment, batteries and waste prevents the potential

contamination of nature with the hazardous substances which may be present in electrical and electronic products and equipment. Your Bang & Olufsen retailer will advise you of the correct way of disposal in your country.

*If a product is too small to be marked with the symbol, it will appear in the User guide, on the Guarantee certificate, or on the packaging.*

---

*All Bang & Olufsen products comply with applicable environmental legislation throughout the world.*



351081011020008



